

**THROUGH FRAME
INSTALLATION**

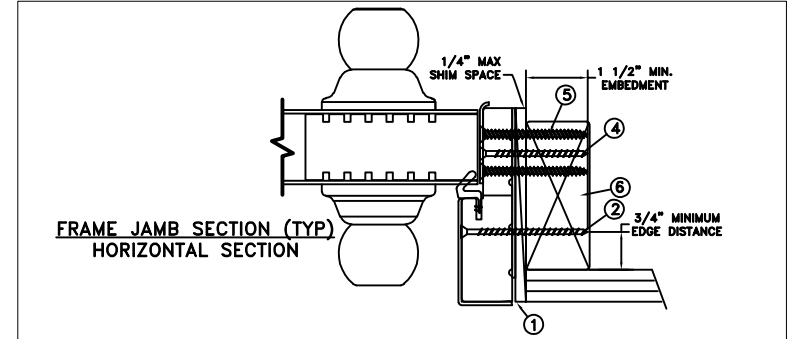
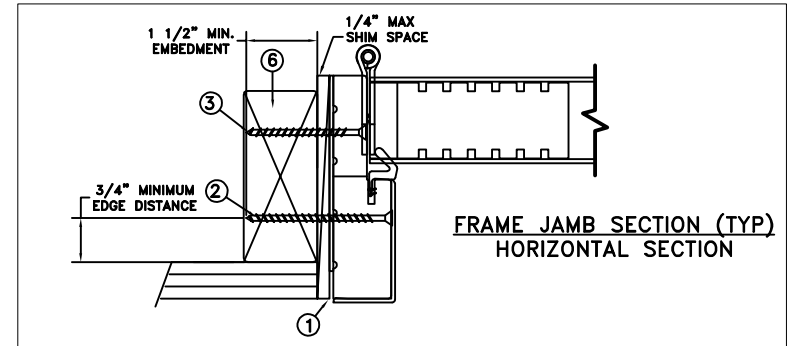

MAXIMUM FRAME	DP	IMPACT
37-3/8" x 81-11/16"	+65/-70	NO

Installation Notes:

1. Seal flange/frame to substrate. Sill shall be set on a continuous serpentine bead of structural grade silicone caulk (typ.).
2. Use #9 SFH or greater fastener through the head & side jambs with sufficient length to penetrate a minimum of 1 1/2" into the wood framing. For 2x wood frame substrate (min. S.G. = 0.42)
3. Use (1) #9 x 2 1/2" TFH or greater fastener through each Hinge with sufficient length to penetrate a minimum of 1 1/2" into the wood framing.
4. Use (2) #8 x 2" SFH or greater fastener through strike plate with sufficient length to penetrate a minimum of 1 1/2" into the wood framing
5. Use (4) #10 x 3" PFH or greater fastener through deadbolt strike plate with sufficient length to penetrate a minimum of 1 1/2" into the wood framing
6. Host structure (wood buck, masonry, steel) to be designed and anchored to properly transfer all loads to the structure. The host structure is the responsibility of the architect or engineer of record for the project of installation.

General Notes:

1. The product shown herein is designed, tested and manufactured to comply with the wind load criteria of the adopted International Building Code (IBC), the International Residential Code (IRC), the Florida Building Code (FBC) including HVHZ and the industry requirement for the stated conditions.
2. All glazing shall conform to ASTM E1300.
3. Use structural or composite shims where required.

This schedule addresses only the fasteners required to anchor the unit to achieve the rated design pressure and impact performance (where applicable) up to the size limitations noted. It is not intended as a guide to the installation process and does not address the sealing consideration that may arise in different wall conditions. For the complete installation procedure, see the instructions packaged with the unit or go to www.jeld-wen.com.

DISCLAIMER:

This drawing and its contents are confidential and are not to be reproduced or copied in whole or in part or used or disclosed to others except as authorized by JELD-WEN Inc.

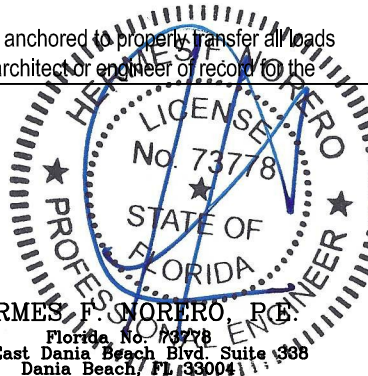

HERMES F. SORERO, P.E.
 Florida No. 73778
 398 East Dania Beach Blvd Suite 338
 Dania Beach, FL 33004

DATE: 05/15/18	JELD WEN 3737 LAKEPORT BLVD. KLAMATH FALLS OR, 97601 PHONE: (800) 535-3936		
DRAWN BY: A. MCMILLAN			
CHECKED BY: D. VEZO	ARCHITECTURAL FIBERGLASS OPAQUE INSWING DOOR NON-IMPACT HVHZ		
APPROVED BY: D. VEZO			
PART/PROJECT No.:			
IDENTIFIER No. I1290.03-301-47 R0	CAD DWG. No.:	REV: A	SHEET 1 of 5

MASONRY STRAP INSTALLATION

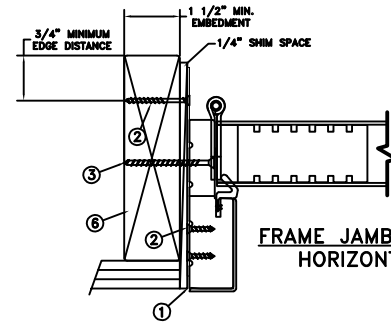
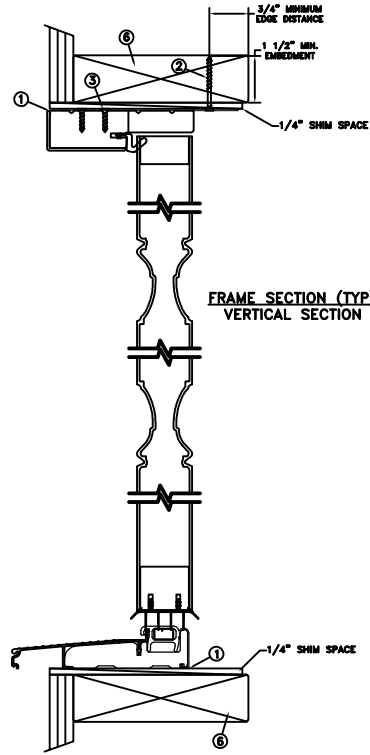
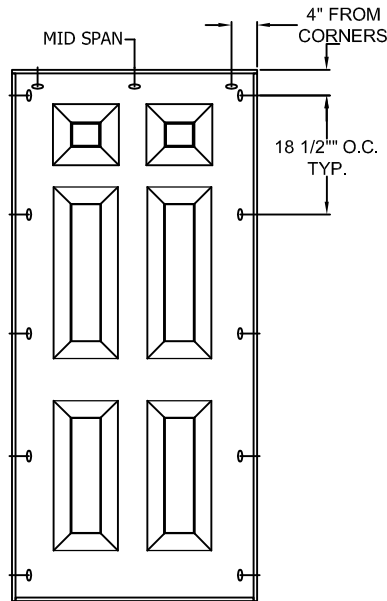

FRAME JAMB SECTION (TYP)
HORIZONTAL SECTION

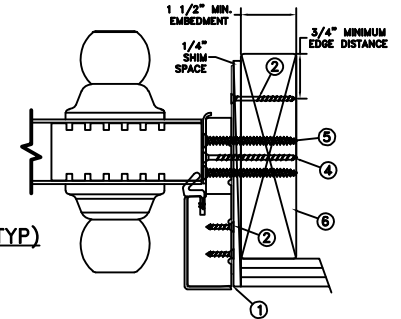

FRAME JAMB SECTION (TYP)
HORIZONTAL SECTION

Installation Notes:

1. Seal flange/frame to substrate. Sill shall be set on a continuous serpentine bead of structural grade silicone caulk (typ.).
2. Use 2 - #10 PFH or larger fasteners through masonry strap with sufficient length to penetrate a minimum of 1 1/2" into the masonry or buck.. For concrete (min. fc = 2000 psi) or masonry substrate (CMU shall adhere to ASTM C90), And through masonry strap into jamb without penetrating through the jamb into product causing visibility or collateral damage to product.
3. Use (1) #9 x 2 1/2" TFH or greater fastener through each Hinge with sufficient length to penetrate a minimum of 1 1/2" into the wood framing.
4. Use (2) #8 x 2" SFH or greater fastener through strike plate with sufficient length to penetrate a minimum of 1 1/2" into the wood framing.
5. Use (4) #10 x 3" PFH or greater fastener through deadbolt strike plate with sufficient length to penetrate a minimum of 1 1/2" into the wood framing.
6. Host structure (wood buck, masonry, steel) to be designed and anchored to properly transfer all loads to the structure. The host structure is the responsibility of the architect or engineer of record for the project of installation.

This schedule addresses only the fasteners required to anchor the unit to achieve the rated design pressure and impact performance (where applicable) up to the size limitations noted. It is not intended as a guide to the installation process and does not address the sealing consideration that may arise in different wall conditions. For the complete installation procedure, see the instructions packaged with the unit or go to www.jeld-wen.com.

DISCLAIMER:

This drawing and its contents are confidential and are not to be reproduced or copied in whole or in part or used or disclosed to others except as authorized by JELD-WEN Inc.

MAXIMUM FRAME	DP	IMPACT
37-3/8" x 81-11/16"	+65/-70	NO

General Notes:

1. The product shown herein is designed, tested and manufactured to comply with the wind load criteria of the adopted International Building Code (IBC), the International Residential Code (IRC), the Florida Building Code (FBC) including HVHZ and the industry requirement for the stated conditions.
2. All glazing shall conform to ASTM E1300.
3. Use structural or composite shims where required.

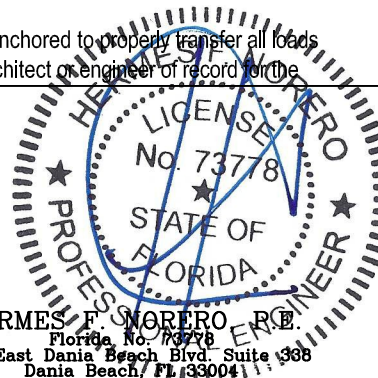

HERMES F. MORERO, P.E.
Florida No. 73778
398 East Dania Beach Blvd Suite 338
Dania Beach, FL 33004

DATE: 05/15/18		3737 LAKEPORT BLVD. KLAMATH FALLS OR, 97601 PHONE: (800) 535-3936
DRAWN BY: A. MCMILLAN		SCALE: NTS
CHECKED BY:	TITLE: ARCHITECTURAL FIBERGLASS OPAQUE INSWING NON-IMPACT HVHZ	
APPROVED BY: CERT MGR	PART/PROJECT No.: D015337	
IDENTIFIER No. I1290.03-301-47 R0	CAD DWG. No.: DRAWING NAME	REV: A SHEET 2 of 5

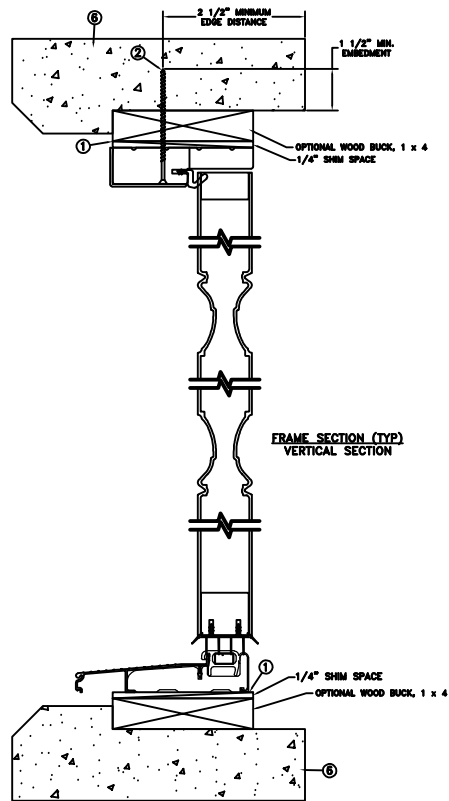
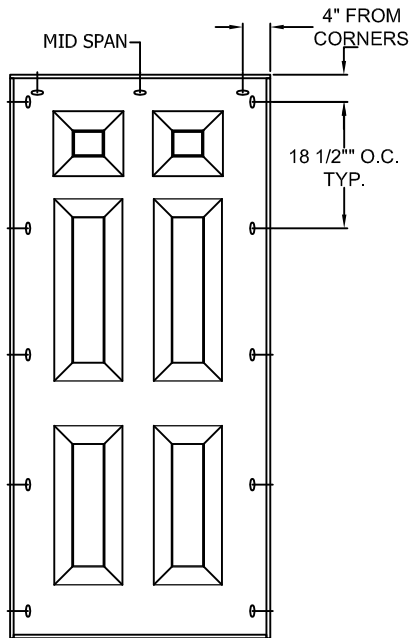

CONCRETE/MASONRY INSTALLATION

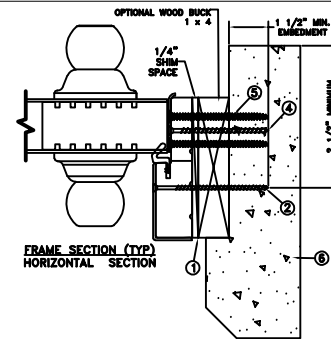
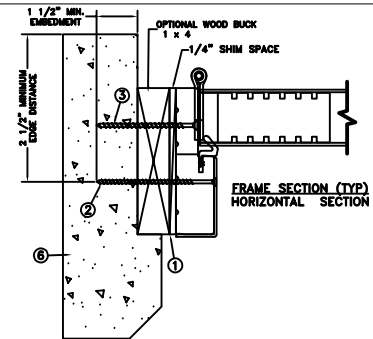

MAXIMUM FRAME	DP	IMPACT
37-3/8" x 81-11/16"	+65/-70	NO

Installation Notes:

1. Seal flange/frame to substrate. Sill shall be set on a continuous serpentine bead of structural grade silicone caulk (typ.).
2. Use 1/4" Elco Tapcon or equivalent fasteners through frame with sufficient length to penetrate a minimum of 1 1/2" into concrete or masonry at each location with a 2 1/2" min. from edge distance. For concrete (min. fc = 2000 psi) or masonry substrate (CMU shall adhere to ASTM C90).
3. Use (1) #9 x 2 1/2" TFH or greater fastener through each Hinge with sufficient length to penetrate a minimum of 1 1/2" into the wood framing.
4. Use (2) #8 x 2" SFH or greater fastener through strike plate with sufficient length to penetrate a minimum of 1 1/2" into the wood framing.
5. Use (4) #10 x 3" TFH or greater fastener through deadbolt strike plate with sufficient length to penetrate a minimum of 1 1/2" into the wood framing.
6. Host structure (wood buck, masonry, steel) to be designed and anchored to properly transfer all loads to the structure. The host structure is the responsibility of the architect or engineer of record for the project of installation.

General Notes:

1. The product shown herein is designed, tested and manufactured to comply with the wind load criteria of the adopted International Building Code (IBC), the International Residential Code (IRC), the Florida Building Code (FBC) including HVHZ and the industry requirement for the stated conditions.
2. All glazing shall conform to ASTM E1300.
3. Use structural or composite shims where required.

This schedule addresses only the fasteners required to anchor the unit to achieve the rated design pressure and impact performance (where applicable) up to the size limitations noted. It is not intended as a guide to the installation process and does not address the sealing consideration that may arise in different wall conditions. For the complete installation procedure, see the instructions packaged with the unit or go to www.jeld-wen.com.

DISCLAIMER:

This drawing and its contents are confidential and are not to be reproduced or copied in whole or in part or used or disclosed to others except as authorized by JELD-WEN Inc.

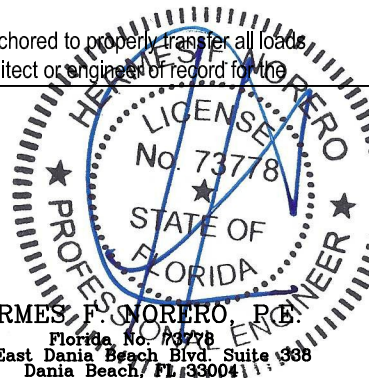

DATE: 05/15/18	JELD WEN 3737 LAKEPORT BLVD. KLAMATH FALLS OR, 97601 PHONE: (800) 535-3936		
DRAWN BY: A. MCMILLAN			
CHECKED BY: D. VEZO	ARCHITECTURAL FIBERGLASS INSWING OPAQUE NON-IMPACT HVHZ		
APPROVED BY: D. VEZO			
PART/PROJECT No.:			
IDENTIFIER No. I1290.03-301-47 R0	CAD DWG. No.:	REV: A	SHEET 3 of 5
	DRAWING NAME		

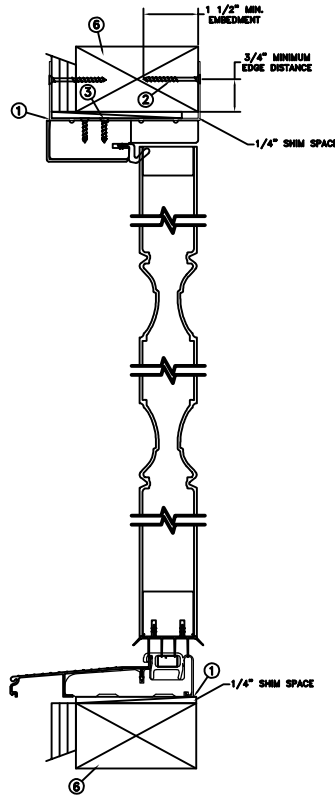
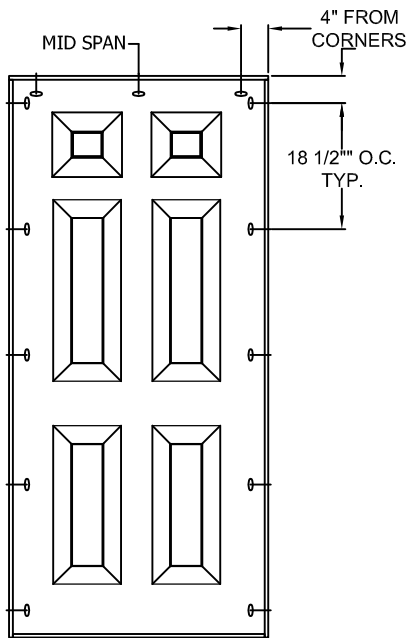

MASONRY STRAP INSTALLATION

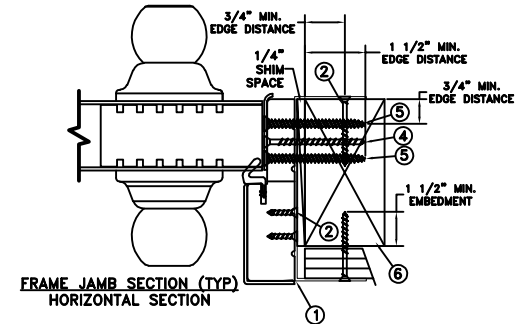
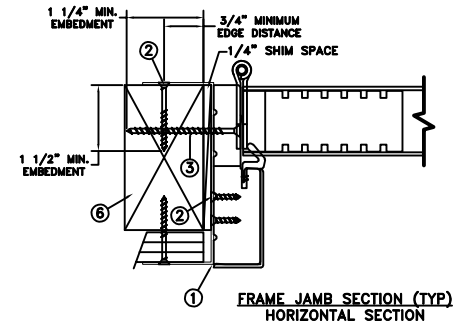

MAXIMUM FRAME	DP	IMPACT
37-3/8" x 81-11/16"	+65/-70	NO

Installation Notes:

1. Seal flange/frame to substrate. Sill shall be set on a continuous serpentine bead of structural grade silicone caulk (typ.).
2. Use min. (2) - #10 PFH or larger fasteners through masonry strap with sufficient length to penetrate a minimum of 1 1/2" into the buck. Bend straps around both sides of the buck. Use (2) into jamb without penetrating through the jamb into product causing visibility or collateral damage to product.
3. Use (1) #9 x 2 1/2" TFH or greater fastener through each Hinge with sufficient length to penetrate a minimum of 1 1/2" into the wood framing.
4. Use (2) #8 x 2" SFH or greater fastener through strike plate with sufficient length to penetrate a minimum of 1 1/2" into the wood framing.
5. Use (4) #10 x 3" PFH or greater fastener through deadbolt strike plate with sufficient length to penetrate a minimum of 1 1/2" into the wood framing.
6. Host structure (wood buck, masonry, steel) to be designed and anchored to properly transfer all loads to the structure. The host structure is the responsibility of the architect or engineer of record for the project of installation.

General Notes:

1. The product shown herein is designed, tested and manufactured to comply with the wind load criteria of the adopted International Building Code (IBC), the International Residential Code (IRC), the Florida Building Code (FBC) including HVHZ and the industry requirement for the stated conditions.
2. All glazing shall conform to ASTM E1300.
3. Use structural or composite shims where required.

This schedule addresses only the fasteners required to anchor the unit to achieve the rated design pressure and impact performance (where applicable) up to the size limitations noted. It is not intended as a guide to the installation process and does not address the sealing consideration that may arise in different wall conditions. For the complete installation procedure, see the instructions packaged with the unit or go to www.jeld-wen.com.

DISCLAIMER:

This drawing and its contents are confidential and are not to be reproduced or copied in whole or in part or used or disclosed to others except as authorized by JELD-WEN Inc.

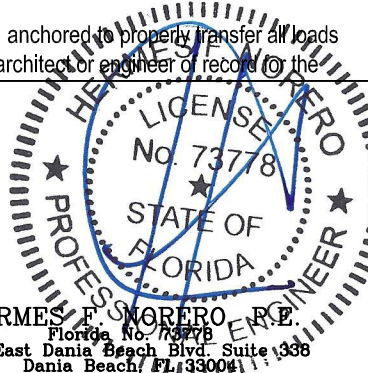

HERMES F. SNORERO, P.E.
 Florida No. 73778
 398 East Dania Beach Blvd, Suite 1338
 Dania Beach, FL 33004

	DATE: 05/15/18	JELD-WEN 3737 LAKEPORT BLVD. KLAMATH FALLS OR, 97601 PHONE: (800) 535-3936
DRAWN BY: A. MCMILLAN	SCALE: NTS	
CHECKED BY: D. VEZO	TITLE: ARCHITECTURAL FIBERGLASS INSWING OPAQUE NON-IMPACT HVHZ	
APPROVED BY: D. VEZO		
PART/PROJECT No.: D015337		
IDENTIFIER No. I1290.03-301-47 R0	CAD DWG. No.: DRAWING NAME	REV: A SHEET 4 of 5

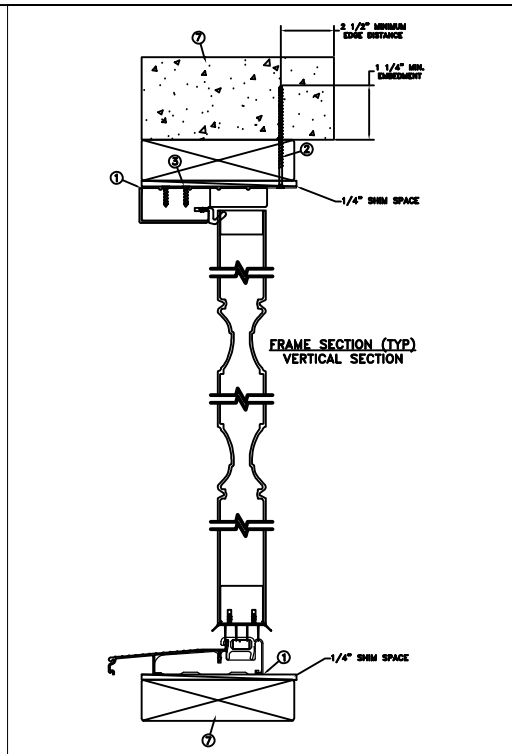
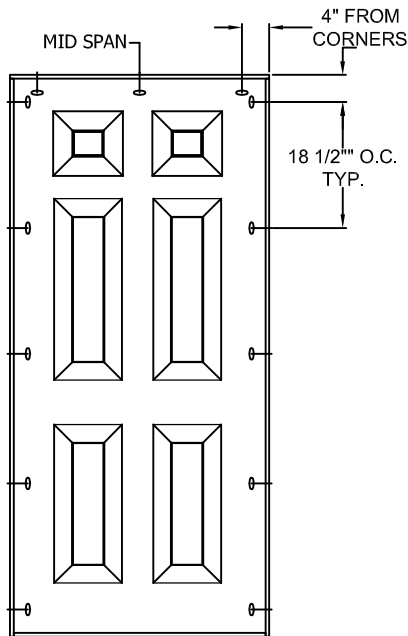

MASONRY STRAP CONCRETE INSTALLATION

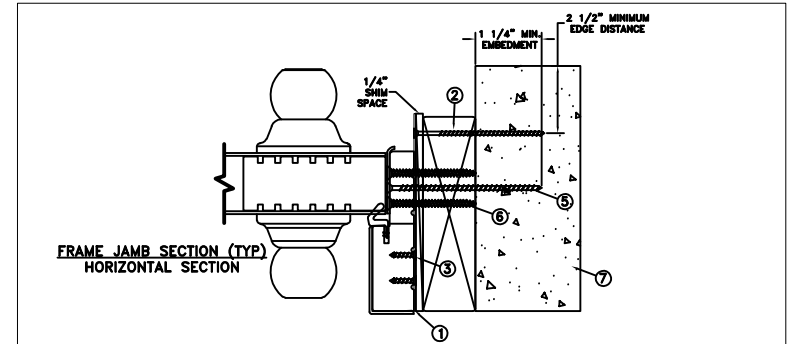
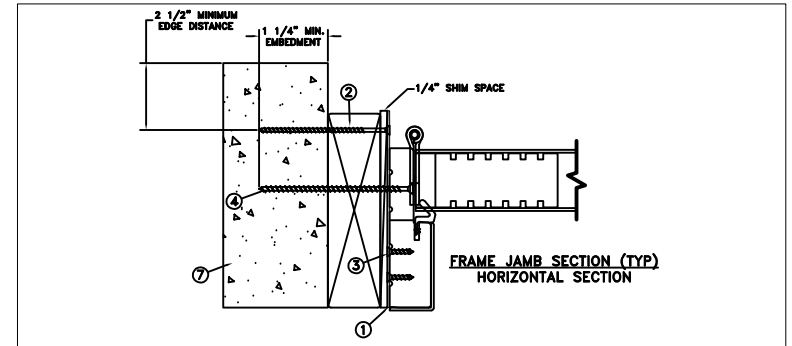

Installation Notes:

1. Seal flange/frame to substrate. Sill shall be set on a continuous serpentine bead of structural grade silicone caulk (typ.).
2. Use (2) - 3/16" Elco Tapcon or equivalent fasteners through masonry strap with sufficient length to penetrate a minimum of 1 1/2" into concrete or masonry at each location with a 2 1/2" min. from edge distance. For concrete (min. fc = 2000 psi) or masonry substrate (CMU shall adhere to ASTM C90).
3. Use min. 2 - #10 PFH or larger fasteners through masonry strap into jamb without penetrating through the jamb into product causing visibility or collateral damage to product.
4. Use (1) #9 x 2 1/2" TFB or greater fastener through each Hinge with sufficient length to penetrate a minimum of 1 1/2" into the wood framing.
5. Use (2) #8 x 2" SFH or greater fastener through strike plate with sufficient length to penetrate a minimum of 1 1/2" into the wood framing.
6. Use (4) #10 x 3" PFH or greater fastener through deadbolt strike plate with sufficient length to penetrate a minimum of 1 1/2" into the wood framing.
7. Host structure (wood buck, masonry, steel) to be designed and anchored to properly transfer all loads to the structure. The host structure is the responsibility of the architect or engineer of record for the project of installation.

This schedule addresses only the fasteners required to anchor the unit to achieve the rated design pressure and impact performance (where applicable) up to the size limitations noted. It is not intended as a guide to the installation process and does not address the sealing consideration that may arise in different wall conditions. For the complete installation procedure, see the instructions packaged with the unit or go to www.jeld-wen.com.

DISCLAIMER:

This drawing and its contents are confidential and are not to be reproduced or copied in whole or in part or used or disclosed to others except as authorized by JELD-WEN Inc.

MAXIMUM FRAME	DP	IMPACT
37-3/8" x 81-11/16"	+65/-70	NO

General Notes:

1. The product shown herein is designed, tested and manufactured to comply with the wind load criteria of the adopted International Building Code (IBC), the International Residential Code (IRC), the Florida Building Code (FBC) including HVHZ and the industry requirement for the stated conditions.
2. All glazing shall conform to ASTM E1300.
3. Use structural or composite shims where required.

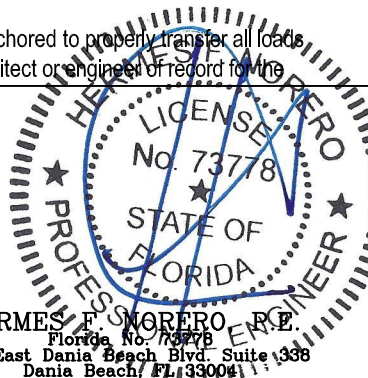

HERMES F. SNORERO, P.E.
 Florida No. 73778
 398 East Dania Beach Blvd, Suite 1338
 Dania Beach, FL 33004

DATE: 05/15/18	JELD-WEN 3737 LAKEPORT BLVD. KLAMATH FALLS OR, 97601 PHONE: (800) 535-3936		
DRAWN BY: A. MCMILLAN			
CHECKED BY: D. VEZO	ARCHITECTURAL FIBERGLASS INSWING OPAQUE NON-IMPACT HVHZ		
APPROVED BY: D. VEZO			
PART/PROJECT No.:D015337			
IDENTIFIER No. I1290.03-301-47 R0	CAD DWG. No.:	REV:	SHEET
	DRAWING NAME	A	5 of 5